

I/O EXPANSION MODULES

4

General Description of I/O Modules

Trio Motion Technology's range of digital and analogue input/output expansion modules are designed to enable simple and scalable I/O extension for Trio's *Motion Coordinators*. The range includes 24V digital input, output, relay and analogue I/O modules, and in the EtherCAT range there is an Axis module to drive 3 pulse+direction or encoder axes.

There are two *Motion Coordinator* I/O expansion systems. One uses EtherCAT for high speed synchronized updating of the IO, the other uses CANbus which allows input/output modules to be distributed individually throughout a machine. Both EtherCAT and CANbus result in much reduced wiring compared with IO that is wired directly to the central controller.

FLEXSLICE ETHERCAT I/O SYSTEM

This makes available a selection of digital and analogue I/O terminals as well as motion modules with pulse + direction outputs designed for precise positioning of stepper and servo motors via suitable drive technology. The digital I/O modules have high-speed functionality, with ON/OFF delays of 210 μ s max, 75 μ s minimum. In addition, analogue modules and axis modules may be fitted to make a superbly tailored system that can be placed remotely from the master if needed.

All Flexslice modules support automatic addressing with the master able to automatically detect and configure the modules on startup. The bus coupler supports up to 16 input/output modules which have a positive mechanical lock and bus connector, making a reliable ~~EBUS~~ connection through the backplane. The complete assembly can be DIN rail mounted.

CANBUS I/O SYSTEM

All CAN Input, Output and I/O modules are DIN rail mounted with the I/O connections located conveniently on the front face. They have been designed with a spaced-saving footprint only 26mm wide so allowing large amounts of Digital and Analogue I/O to be packed in an area no bigger than the average PLC. Address selection is simply done by setting DIP switches that are neatly located under the pull-up flap. LEDs show the I/O state and indicate an error code for straight forward system commissioning and de-bugging. Up to 32 CAN Digital modules and up to 4 Analogue modules may be added to the system.

CANbus is used for communication and control between the *Motion Coordinator* and the CAN I/O modules. CANbus is a tried and tested, well known industrial data link which is reliable, noise immune and flexible.

PRODUCT CODE:

ETHERCAT		CANBUS	
Flexslice EtherCAT Coupler Module	P366	CAN 16-Output Module	P317
Flexslice 16-Out PNP Module	P371	CAN 16-Input Module	P318
Flexslice 16-IN PNP Module	P372	CAN 16-I/O Module	P319
Flexslice 3 axis Step/Encoder Module	P375	CAN Analogue I/O Module	P326
Flexslice 16-Out NPN Module	P376	CAN 8-Relay Module	P327
Flexslice 16-In NPN Module	P377		
Flexslice 8 Analogue Outputs Module	P378		
Flexslice 8 Analogue Inputs Module	P379		

Coupler Module (P366)

The P366 Flexslice EtherCAT Coupler connects EtherCAT with the EtherCAT I/O slices. The coupler converts the passing telegrams from Ethernet 100BASE-T to **EBUS** signal format, and provides power to attached modules.

The coupler is connected to the network via the upper Ethernet interface. The lower RJ45 socket may be used to connect further EtherCAT devices in the same strand. The P366 coupler and system can be installed at any position in the EtherCAT network, making it suitable for operation close to the master or at a remote position.

CONNECTIONS

Power Supply	24V dc ($\pm 20\%$) Class 2 transformer or power supply, 0.8A min
EtherCAT In	RJ45
EtherCAT Out	RJ45

LED'S

RN	Green "RUN" LED
LA	Green EBUS Link/Act LED

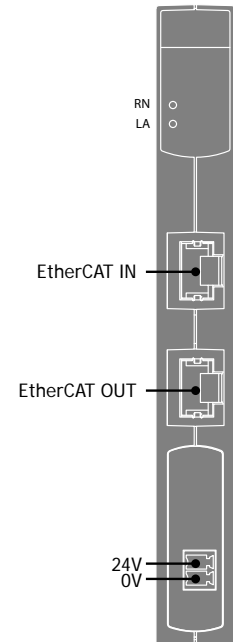

16-Out PNP Module (P371)

The P371 digital output slice connects the binary control signals from the *Motion Coordinator* to the machine's input devices at 24V dc. All 16 outputs are current sourcing (PNP) type and have electrical isolation. Outputs and power connection are via 2 x single-row push-in connectors. The Flexslice module indicates the output signal states via LEDs.

CONNECTIONS

Power Supply	24V dc ($\pm 20\%$) Class 2 transformer or power supply
Output bank 1	8 x 24V dc Outputs, 0.5A max per channel
Output bank 2	8 x 24V dc Outputs, 0.5A max per channel
Max current	4 Amps per bank
Isolation Outputs to EBUS	1,000 V dc
Isolation between banks	1,000 V dc

LED'S

RN	Green "RUN" LED
0 - 15	Yellow LEDs Output status

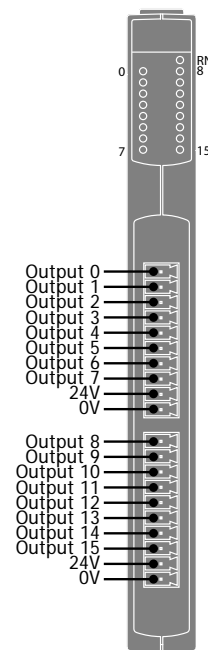

 If both banks are used, each isolated 24V and 0V must be wired.

16-IN PNP Module (P372)

The P372 digital input slice connects 24V dc signals from devices on the machine to the binary control registers in the *Motion Coordinator*. All 16 inputs are current sinking (PNP) type and have electrical isolation. Inputs and power connection are via 2 x single-row push-in connectors. The Flexslice module indicates the input signal states via LEDs.

CONNECTIONS

Power Supply	None
Input bank 1	8 x 24V dc Inputs, 3.5mA typ, 0V common
Input bank 2	8 x 24V dc Inputs, 3.5mA typ, 0V common
Isolation Outputs to EBUS	1,000 V dc
Isolation between banks	1,000 V dc

LED'S

RN	Green "RUN" LED
0 - 15	Yellow LEDs Input status

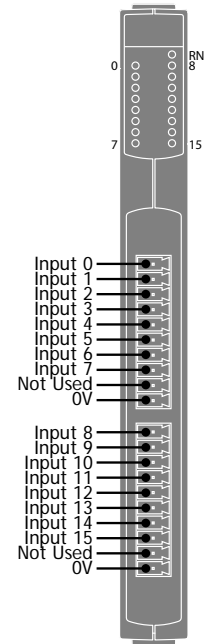

 If both banks are used, each isolated 0V must be wired.

3 Axis Step / ENCODER (P375)

The P375 Flexslice 3 Axis Step /Encoder Module controls up to 3 Stepper motors with Pulse/Direction/Enable or 3 encoders with A, B and Z inputs for each axis. There is also one global watchdog output independent from the axis configuration.

CONNECTIONS

Power Supply	24V dc ($\pm 20\%$) Class 2 transformer or power supply
Axis connector	26 way MDR with latch

Pin	Function	Pin	Function
26	WDOG+	13	WDOG-
25	0V EXT	12	B/DIR2-
24	5V EXT	11	B/DIR2+
23	Z/ENB2-	10	A/STP2-
22	Z/ENB2+	9	A/STP2+
21	0V EXT	8	B/DIR1-
20	5V EXT	7	B/DIR1+
19	Z/ENB1-	6	A/STP1-
18	Z/ENB1+	5	A/STP1+
17	0V EXT	4	B/DIRO-
16	5V EXT	3	B/DIRO+
15	Z/ENB0-	2	A/STP0-
14	Z/ENB0+	1	A/STP0+

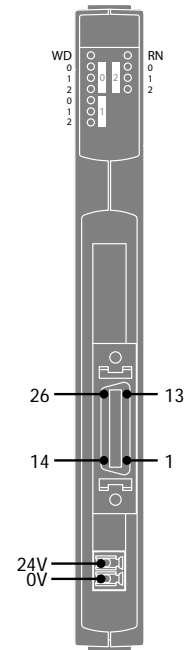

LED'S

Name	LED Colour	LED function
WD	RED	WDOG (ON = Axes disabled)
RN	GREEN	ECAT STATUS

	Stepper Out			Encoder In	
	STEP + DIR	SQR + DIR	QUAD	STEP + DIR	QUAD
0	STEP	STEP	A	STEP	A
1	DIR(F/R)	DIR(F/R)	B	DIR(F/R)	B
2	ENA(ON/OFF)	ENA(ON/OFF)	ENA(ON/OFF)	BLINKING	BLINKING

16-Out NPN (P376)

The P376 digital output slice connects the binary control signals from the *Motion Coordinator* to the machine's input devices, such as relays, contactors, valves, lamps etc. at 24V dc. All 16 outputs are current sinking (NPN) type and have electrical isolation. Outputs and power connection are via 2 x single-row push-in connectors. The Flexslice module indicates the output signal states via LEDs.

CONNECTIONS

Power Supply	24V dc ($\pm 20\%$) Class 2 transformer or power supply
Output bank 1	8 x Outputs, 24V dc 1.0A max per channel
Output bank 2	8 x Outputs, 24V dc 1.0A max per channel
Max current	4 Amps per bank
Isolation Outputs to EBUS	1,000 V dc
Isolation between banks	1,000 V dc

LED'S

RN	Green "RUN" LED
0 - 15	Yellow LEDs Output status

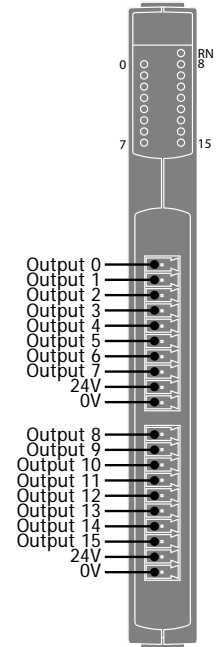

 If both banks are used, each isolated 24V and 0V must be wired.

16-In NPN (P377)

The P377 digital input slice connects 24V dc signals from devices on the machine to the binary control registers in the *Motion Coordinator*. All 16 inputs are current sourcing (NPN) type and have electrical isolation. Inputs and power connection are via 2 x single-row push-in connectors. The Flexslice module indicates the input signal states via LEDs.

CONNECTIONS

Power Supply	24V dc ($\pm 20\%$) Class 2 transformer or power supply
Input bank 1	8 x NPN Inputs, 3.5mA typ, 24V dc common
Input bank 2	8 x NPN Inputs, 3.5mA typ, 24V dc common
Isolation Outputs to EBUS	1,000 V dc
Isolation between banks	1,000 V dc

LED'S

RN	Green "RUN" LED
0 - 15	Yellow LEDs Input status

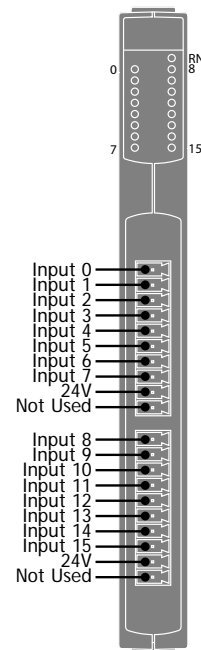

 If both banks are used, each isolated 24V Must be wired.

8 Analogue Outputs (P378)

The P378 Flexslice 8 Analogue Output module has eight programmable voltage range output terminals, each output has a resolution of 12 bit. The 8 single ended outputs have a common 0V potential and are brought out to a single row push-in connector.

CONNECTIONS

Power Supply	None
Analogue Outputs	8 x +/-10V, 0 ... +10V
Output current	5mA (max)
Output Resistance	16Ω internal
Isolation Outputs to EBUS	1,000 V dc

LED'S

RN	Green "RUN" LED
S0 - S1	Yellow LEDs Output status

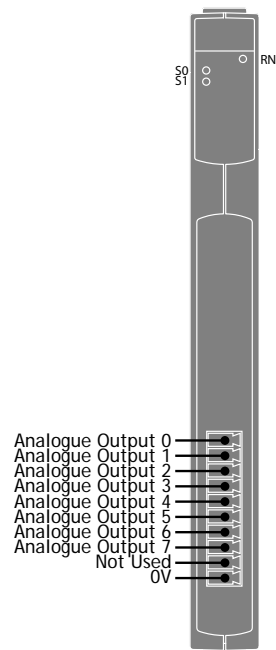

8 Analogue Inputs (P379)

The P379 Flexslice 8 Analogue Input module has eight programmable voltage range input terminals, each digitised to a resolution of 12 bit. The 8 single ended inputs have a common 0V potential and are brought out to a single row push-in connector.

CONNECTIONS

Power Supply	None
Analogue Inputs	8 x +/-10V, 0 ... +10V
Overtoltage protection	+/- 25V
Input resistance	>31k Ω internal
Isolation Outputs to EBUS	1,000 V dc

LED'S

RN	Green "RUN" LED
S0 - S1	Yellow LEDs Output status

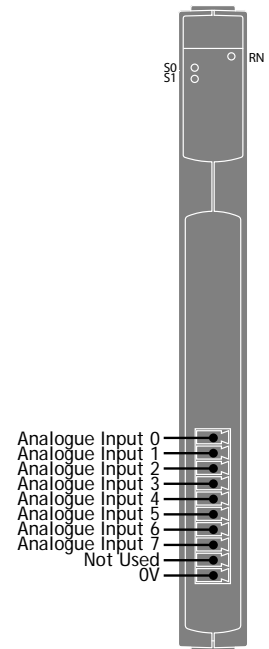

Assembling The System

One station consists of a P366 coupler and up to 16 Flexslice EtherCAT modules.

1. Align a Flexslice Module against the right hand side of the P366 Coupler Module.
2. Slide back the “click-to-lock” mechanism into position.

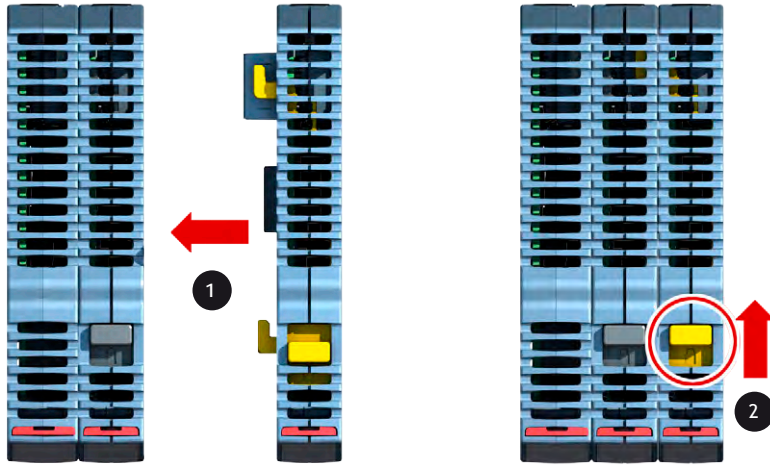

Removal of Flexslices is the opposite of this procedure.

Connectors

POWER (24V) CONNECTOR:

Note: Use ferrules on all wires for best connection.

1. Connection: Push wire into hole of connector. No tools are necessary.
2. Removal: Push screwdriver against coloured button to release wire and pull wire out.

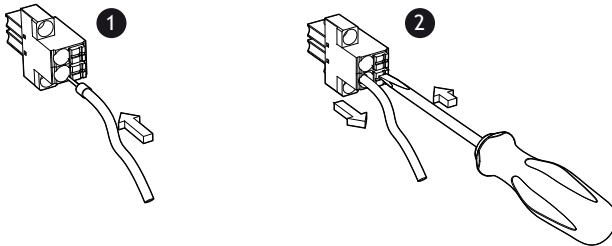

DATA CONNECTION (ALL MODULES):

Note: Use ferrules on all wires for best connection.

1. Connection: Push wire into hole of connector. No tools are necessary.
2. Removal: Push screwdriver against coloured button to release wire and pull wire out.

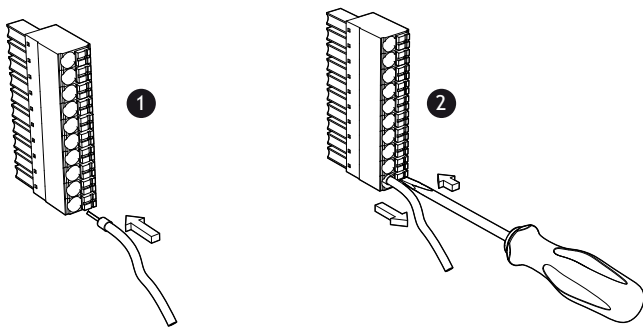

Dimensions

P366 Coupler

P367 - P379

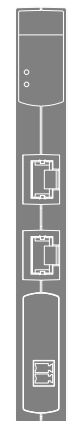

17mm

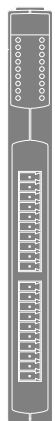

15mm

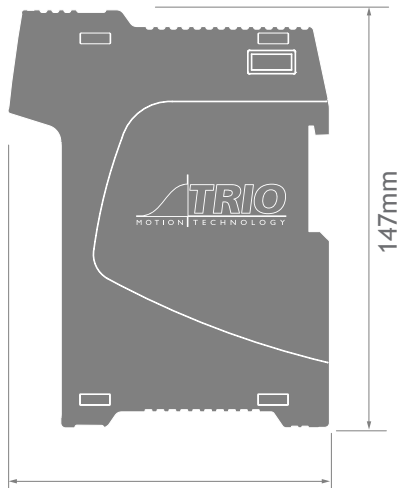

147mm

107mm

Controller setup

All *Motion Coordinators* are configured by default to recognize when Trio Flexslice IO is connected to the EtherCAT network. EtherCAT will go to Operational State and all Inputs and Outputs will be continuously updated at the `SERVO _ PERIOD` rate. Usually the `SERVO _ PERIOD` is 1000 microseconds, but this is adjustable. All setup of the Flexslice IO is made by adding parameter values to the `MC _ CONFIG` configuration file in the *Motion Coordinator*.

There are no Address switches on the Flexslice IO modules.

DIGITAL I/O P371, P372, P376 & P377

There are no adjustable parameters for the digital IO. Operation is simply the function provided by the module fitted. For example choose between NPN and PNP inputs by choosing the correct hardware part number, either P372 or P377.

ANALOGUE I/O P378 & P379

Analogue I/O is configurable for the following ranges.

-10V to +10V (DEFAULT)

-5V to +5V

0V to +10V

0V to +5V

FLEXSLICE AXIS MODULE P375

The P375 has 3 axes which can be configured independently by software. Axis configuration is made by setting parameters in the *Motion Coordinator* `MC _ CONFIG` file.



Do not set the `ATYPE` by program. Always use the `DRIVE _ MODE` and `DRIVE _ PROFILE`

DRIVE_MODE	DRIVE_PROFILE	Function	ATYPE
0	See mode 1	Default mode on power up, same as DRIVE_MODE 1	65
1	0	Pulse and Direction output with Enable output	65
	1	Quadrature output with Enable output	
	2	Square wave and Direction out with Enable output	
5	6	Incremental encoder with Z input	69
	7	Pulse and Direction feedback with Z input	



The EtherCAT network must be reinitialised after changing the drive mode and profile.



New modes will be available from serial number P375-00100 and onwards.

EXAMPLE AXIS SETUP

Initialise axis 1 as a P375 stepper axis. The motor has 8192 steps per turn. Set the Following error limit to 2 turns of the motor. Set UNITS to allow for the divide by 256 in the P375 hardware. Set ENCODER _ RATIO to match the MPOS to the DPOS.

```

BASE(1)
FE _ LIMIT = 8192*256*2
UNITS = 256
ENCODER _ RATIO(256, 1)
SPEED = 10000 ' 10,000 steps per second
ACCEL = 50000 ' accelerate in 0.2 seconds
DECEL = 50000
SERVO = ON ' Start axis control in the firmware
AXIS _ ENABLE = ON ' Set the axis enable output ON
WDOG = ON ' set master enable ON

```

IOMAP

The map of digital and analogue IO can be found within *Motion Perfect* by typing IOMAP(2) in the command line terminal #0.

```

IOMAP(2)
Digital Input map :
  0-   7 : Built-in Inputs
  8-  15 : Built-in Bi-Directional IO
 16-1023 : Virtual

Digital Output map :
  0-   7 : Reserved
  8-  15 : Built-in Bi-Directional IO
 16-  31 : ECAT Output Module @ Slot 0 (Auto Inc Address = 5)
 32-  47 : ECAT Output Module @ Slot 0 (Auto Inc Address = 6)
 48-  63 : ECAT Output Module @ Slot 0 (Auto Inc Address = 7)

Analogue Input map :
  0-   7 : ECAT Input Module @ Slot 0 (Auto Inc Address = 3) [12-bit,
bipolar]

Analogue Output map :
  0-   7 : Reserved
  8-  15 : ECAT Output Module @ Slot 0 (Auto Inc Address = 4) [12-
bit, bipolar]

```

CAN 16-Output Module (P317)

The Trio CAN 16 Output module offers a compact DIN rail mounted relay input expansion capability for all Trio *Motion Coordinators*. Using remote I/O on the Trio CANbus can significantly reduce the machine wiring.

Up to 16 output modules may be connected to the CAN network which may be up to 100m long. This provides up to 256 distributed output channels at 24Vdc level. All outputs are short-circuit proof and completely isolated from the CANbus. P317 modules may be mixed on the same bus, with other types of Trio CAN I/O modules on the same network to build the I/O configuration required for the system.

Convenient disconnect terminals are used for all I/O connections.

CANBUS

The CANbus port has over voltage and reverse polarity protection. Various protocols can be selected using the configuration switches.

24V OUTPUT CHANNELS

The P317 has two banks of eight outputs, both banks of outputs are electrically isolated and require their own 24V and 0V. Output channels have a protected 24V sourcing output connected to the output pin. The output circuit has electronic over-current protection and thermal protection which shuts the output down when the current exceeds 250mA.

Care should be taken to ensure that the 250mA limit for the output circuit is not exceeded, and that the total load for the group of 8 outputs does not exceed 1 amp.

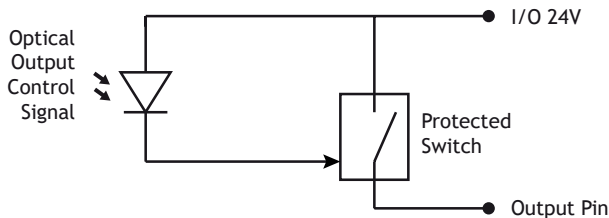
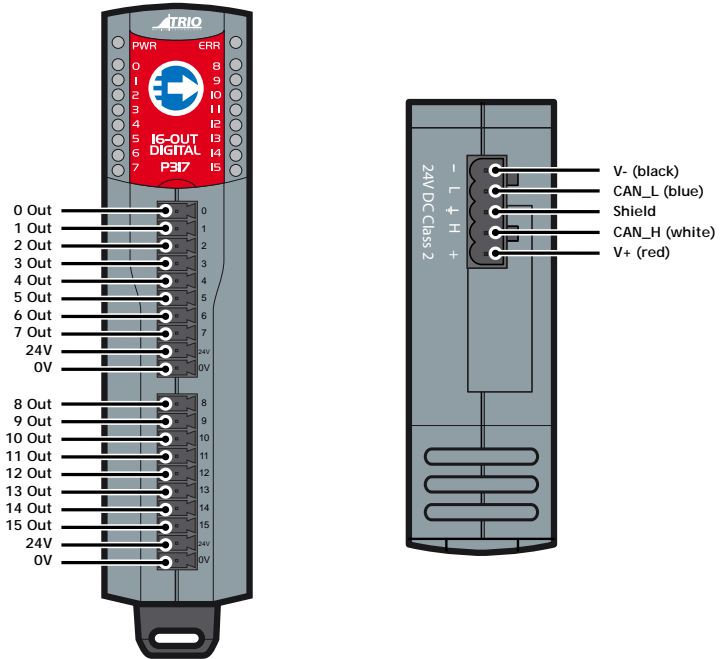

With no load, the outputs may 'float' up to 24V even when off. Fit a load resistor, for example 10k, when bench testing the P317.

LED INDICATORS

The green power (PWR) LED and red error (ERR) LED display the status of the CAN I/O module. The actual status displayed will depend on the protocol selected.

The status LEDs marked 0 - 15 represent the output channels 0 - 15 of the module. The actual outputs as seen by the *Motion Coordinator* software will depend on the modules' address.

CONFIGURATION SWITCHES

The switches are hidden under the display window. These can be adjusted to set the module address, protocol and data rate.

SPECIFICATION P317

Outputs:	16 24 Volt output channels with 2500V isolation
Configuration:	16 output channels
Output Capacity:	1A per bank of 250mA / channel
Protection:	Outputs are overcurrent and over temperature protected
Indicators:	Individual status LED's
Address Setting:	Via DIP switches
Power Supply:	24V dc, Class 2 transformer or power source 18 ... 29V dc / 1.5W.
Mounting:	DIN rail mount
Size:	26mm wide 85mm deep 130mm high
Weight:	128g
CAN:	500kHz, Up to 256 expansion I/O channels
EMC:	EN 61000-6-2 : 2005 Industrial Noise Immunity / EN 61000-6-4 : 2007 Industrial Noise
CAN protocol:	Trio CAN I/O or CANopen DS401.

CAN 16-Input Module (P318)

The Trio CAN 16 Input module offers a compact DIN rail mounted relay input expansion capability for all Trio *Motion Coordinators*. Using remote I/O on the Trio CANbus can significantly reduce the machine wiring.

Up to 16 input modules may be connected to the CAN network which may be up to 100m long. This provides up to 256 distributed input channels at 24Vdc level. All input points are high level (24V in = ON) and completely isolated from the CANbus. P318 modules may be mixed on the same bus, with other types of Trio CAN I/O modules on the same network to build the I/O configuration required for the system.

Convenient disconnect terminals are used for all I/O connections.

CANBUS

The CANbus port has over voltage and reverse polarity protection. Various protocols can be selected using the configuration switches.

24V INPUT CHANNELS

The P318 has two banks of eight inputs, both banks of outputs are electrically isolated and have independent 0V. Input channels are opto-isolated 24V, which are designed to be ON when the input voltage is greater than 18 Volts and OFF when the signal voltage is below 2V. The input has a 6k Ω resistor in series and so provides a load of approximately 3.5mA at 24V.

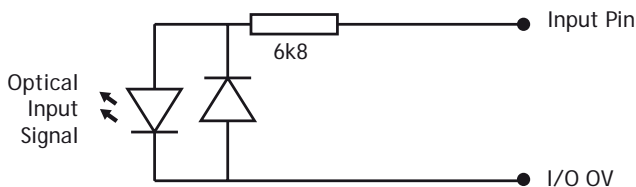

LED INDICATORS

The green power (PWR) LED and red error (ERR) LED display the status of the CAN I/O module. The actual status displayed will depend on the protocol selected.

The status LEDs marked 0 - 15 represent the input channels 0 - 15 of the module. The actual input as seen by the *Motion Coordinator* software will depend on the modules' address.

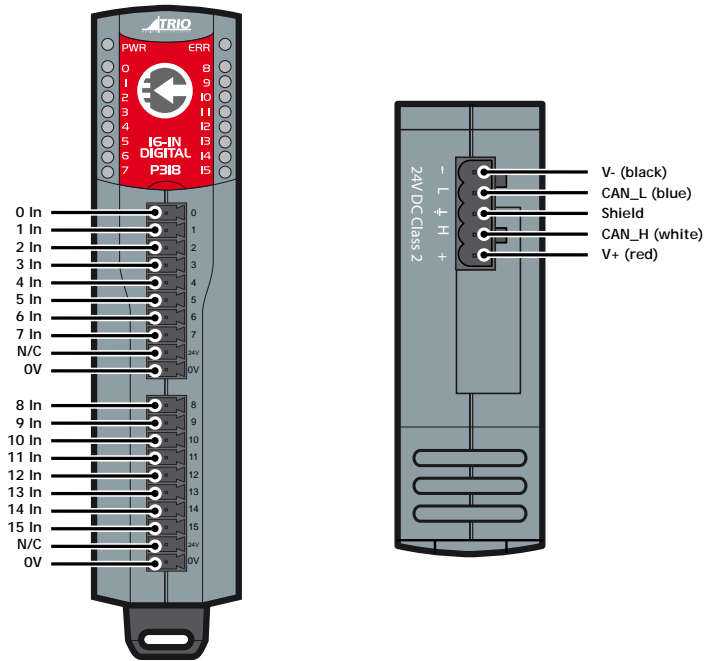

CONFIGURATION SWITCHES

The switches are hidden under the display window. These can be adjusted to set the module address, protocol and data rate.

SPECIFICATION P318

Inputs:	16 24 Volt input channels with 2500V isolation
Configuration:	16 input channels
Protection:	Inputs are reverse polarity protected
Indicators:	Individual status LED's
Address Setting:	Via DIP switches
Power Supply:	24V dc, Class 2 transformer or power source 18 ... 29V dc / 1.5W.
Mounting:	DIN rail mount
Size:	26mm wide 85mm deep 130mm high
Weight:	128g
CAN:	500kHz, Up to 256 expansion I/O channels
EMC:	EN 61000-6-2 : 2005 Industrial Noise Immunity / EN 61000-6-4 : 2007 Industrial Noise Emissions
CAN protocol:	Trio CAN I/O or CANopen DS401.

CAN 16-I/O Module (P319)

The Trio CAN 16 Input/ Output module offers a compact DIN rail mounted relay input expansion capability for all Trio *Motion Coordinators*. Using remote I/O on the Trio CANbus can significantly reduce the machine wiring.

Up to 16 I/O modules may be connected to the CAN network which may be up to 100m long. This provides up to 256 distributed bi-directional input/output channels at 24Vdc level. All input points are high level (24V in = ON) all outputs are short-circuit proof and the I/O is completely isolated from the CANbus. P319 modules may be mixed on the same bus, with other types of Trio CAN I/O modules on the same network to build the I/O configuration required for the system.

Convenient disconnect terminals are used for all I/O connections.

CANBUS

The CANbus port has over voltage and reverse polarity protection. Various protocols can selected using the configuration switches.

24V INPUT/ OUTPUT CHANNELS

The P319 has two banks of eight bi-directional input/ outputs, both banks are electrically isolated and require their own 24V and 0V. Input/output channels are bi-directional, so can be used as an input or output. Bi-directional inputs have a protected 24V sourcing output connected to the same pin. If the output is unused, the pin may be used as an input in the program. The output circuit has electronic over-current protection and thermal protection which shuts the output down when the current exceeds 250mA.

Care should be taken to ensure that the 250mA limit for the output circuit is not exceeded, and that the total load for the group of 8 outputs does not exceed 1 amp.

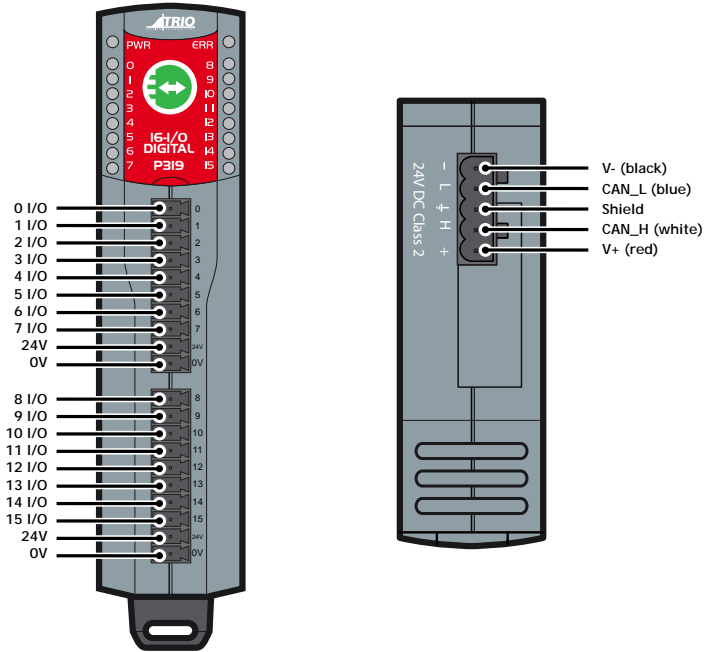

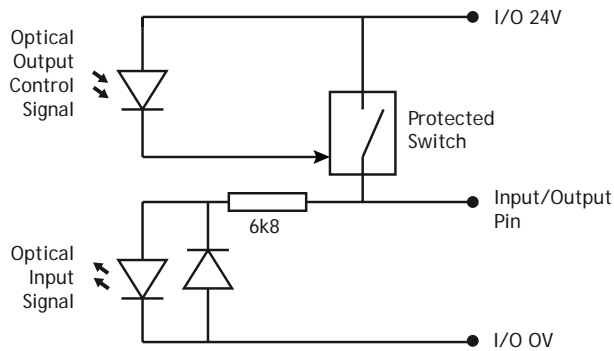

LED INDICATORS

The green power (PWR) LED and red error (ERR) LED display the status of the CAN I/O module. The actual status displayed will depend on the protocol selected.

The status LEDs marked 0 - 15 represent the I/O channels 0 - 15 of the module. The actual I/O as seen by the *Motion Coordinator* software will depend on the modules' address.

CONFIGURATION SWITCHES

The switches are hidden under the display window. These can be adjusted to set the module address, protocol and data rate.

SPECIFICATION P319

Inputs:	16 24 Volt input channels with 2500V isolation
Outputs:	16 24 Volt output channels with 2500V isolation
Configuration:	16 input/output channels
Output Capacity:	Outputs are rated at 250mA/channel. (1 Amp total/bank of 8 I/O's)
Protection:	Outputs are overcurrent and over temperature protected
Indicators:	Individual status LED's
Address Setting:	Via DIP switches
Power Supply:	24V dc, Class 2 transformer or power source. 18 ... 29V dc / 1.5W.
Mounting:	DIN rail mount
Size:	26mm wide 85mm deep 130mm high
Weight:	128g
CAN:	500kHz, Up to 256 expansion I/O channels
EMC:	EN 61000-6-2 : 2005 Industrial Noise Immunity / EN 61000-6-4: 2007 Industrial Noise
CAN protocol:	Trio CAN I/O or CANopen DS401.

CAN Analogue I/O Module (P326)

The Trio CAN Analogue I/O module offers a compact DIN rail mounted relay output expansion capability for all Trio *Motion Coordinators*. Using remote I/O on the Trio CANbus can significantly reduce the machine wiring.

Up to 4 analogue modules may be connected to the CAN network which may be up to 100m long. This provides up to 32 distributed analogue inputs and 16 analogue outputs . Each module provides 8 channels of 12-bit analogue inputs (+/-10v) and 4 channels of 12-bit (+/-10v) analogue outputs. All analogue I/O are completely isolated from the CANbus. P326 modules may be mixed on the same bus, with other types of Trio CAN I/O modules on the same network to build the I/O configuration required for the system.

Convenient disconnect terminals are used for all I/O connections.

CANBUS

The CANbus port has over voltage and reverse polarity protection. Various protocols can be selected using the configuration switches.

INPUT TERMINALS

The 8 analogue inputs are single-ended and have a common 0V. Analogue input nominal impedance = 42k Ohm.

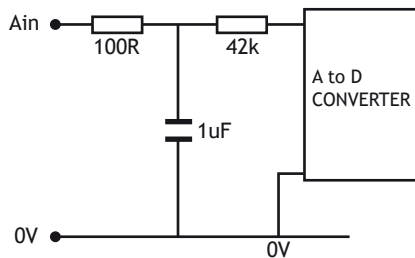

OUTPUT TERMINALS

The 4 analogue outputs are single-ended and have a common 0V. Analogue output nominal impedance = 100 Ohm.

The recommended minimum load resistance on the output is 2k Ohm.

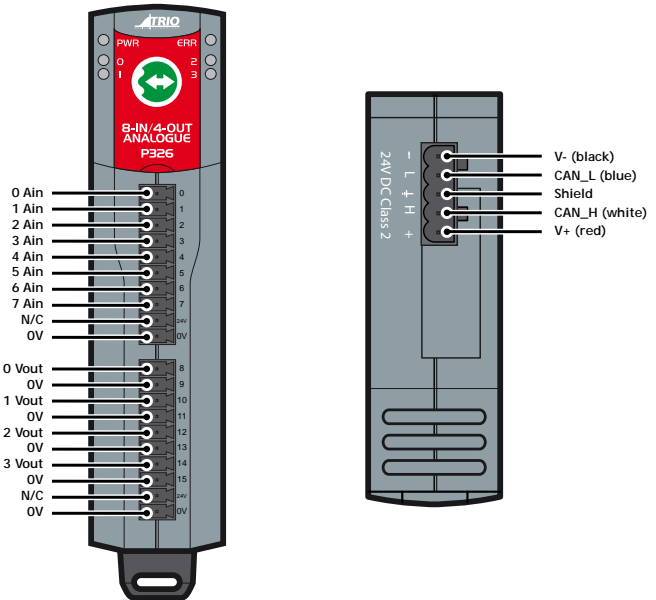

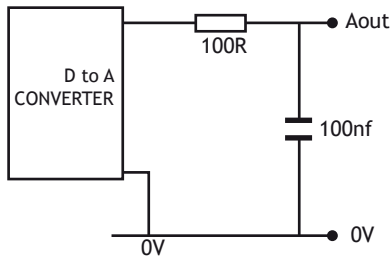

LED INDICATORS

The green power (PWR) LED and red error (ERR) LED display the status of the CAN I/O module. The actual status displayed will depend on the protocol selected.

The status LEDs marked 0 - 3 are only used to display an error.

CONFIGURATION SWITCHES

The switches are hidden under the display window. These can be adjusted to set the module address, protocol and data rate.

SPECIFICATION P326

Analogue Inputs:	8 +/-10 Volt inputs with 500V isolation from CAN bus.
Resolution:	12 bit.
Protection:	Inputs are protected against 24V over voltage.
Analogue Outputs:	4 +/-10 Volt outputs with 500V isolation from CAN bus.
Resolution:	12Bit.
Address Setting:	Via DIP switches.
Power Supply:	24V dc, Class 2 transformer or power source. 18 ... 29V dc / 1.5W.
Mounting:	DIN rail mount.
Size:	26mm wide 85mm deep 130mm high.
Weight:	128g
CAN:	500kHz, Up to 32 analogue input channels and 16 analogue output channels.
EMC:	EN 61000-6-2 : 2005 Industrial Noise Immunity / EN 61000-6-4 : 2007 Industrial Noise Emissions.
CAN Protocol:	Trio CAN I/O or CANopen DS401.

CAN 8-Relay Module (P327)

The Trio CAN 8 Relay module offers a compact DIN rail mounted relay output expansion capability for all Trio *Motion Coordinators*. Using remote I/O on the Trio CANbus can significantly reduce the machine wiring.

Up to 16 relay modules may be connected to the CAN network which may be up to 100m long. This provides up to 128 distributed low power relay channels at up to 30Vdc or 49Vac. Four of the 8 channels in each module are change-over contact and the remaining four are normally-open contacts. All output points are voltage-free contacts and are completely isolated from the CANbus. P327 modules may be mixed on the same bus, with other types of Trio CAN I/O modules on the same network to build the I/O configuration required for the system.

Convenient disconnect terminals are used for all I/O connections.

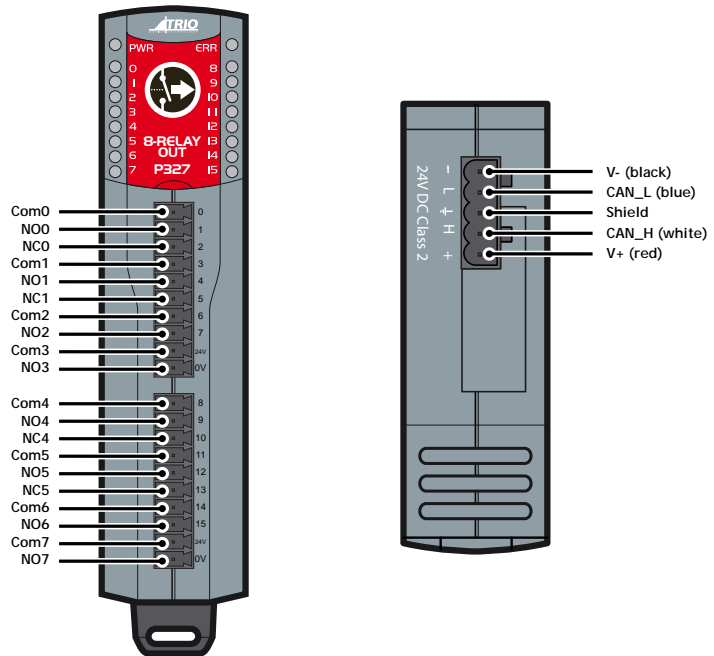

Do not connect 24V and 0V to the bottom two pins (Com3, NO3 and Com7, NO7) on the connectors as the pin connections are different to the details molded into the plastic case.

CANBUS

The CANbus port has over voltage and reverse polarity protection. Various protocols can selected using the configuration switches.

RELAY CHANNELS

Each relay channel is an independent isolated voltage free set of contacts. Channels 0, 1, 4 and 5 are change-over contacts and channels 2, 3, 6 and 7 are normally open contacts only. Each contact is rated at 30Vdc (24 Watts) or 49Vac (62.5 VA). Absolute maximum current for any one contact is 1A under all conditions.

Relay contacts do not have built-in suppression so external EMC suppression components must be fitted as required.



Using the Relay in a circuit where the Relay will be ON continuously for long periods (without switching) can lead to unstable contacts, because the heat generated by the coil itself will affect the insulation, causing a film to develop on the contact surfaces. Be sure to use a fail-safe circuit design that provides protection against contact failure or coil burnout.

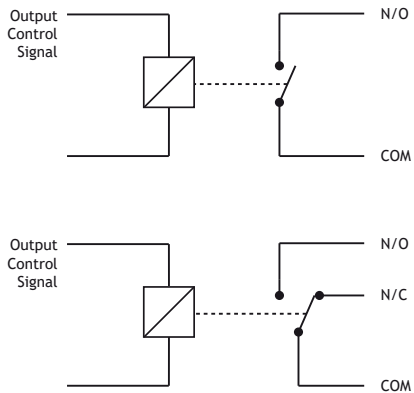

LED INDICATORS

The green power (PWR) LED and red error (ERR) LED display the status of the CAN I/O module. The actual status displayed will depend on the protocol selected.

The status LEDs marked 0 - 7 represent the relay channels 0 - 7 of the module. The actual output as seen by the *Motion Coordinator* software will depend on the modules' address.

CONFIGURATION SWITCHES

The switches are hidden under the display window. These can be adjusted to set the module address, protocol and data rate.

SPECIFICATION P327

Outputs:	8 relays 30Vdc / 49Vac
Configuration:	4 NO relays and 4 change-over relays
Output Capacity:	Maximum switching power per contact: 62.5 VA, 24W (dc) Max current 1 Amp.
Protection:	Outputs to CAN circuit isolation, 1,500V dc.
Indicators:	Individual status LED's
Address Setting:	Via DIP switches
Power Supply:	24V dc, Class 2 transformer or power source. 18 ... 29V dc / 1.5W.
Mounting:	DIN rail mount
Size:	26mm wide 85mm deep 130mm high

Weight:	174g
CAN:	500kHz, Up to 128 expansion relay channels
EMC:	EN 61000-6-2: 2005 Industrial Noise Immunity / EN 61000-6-4: 2007 Industrial Noise
CAN protocol:	Trio CAN I/O or CANopen DS401

Controller I/O mapping

DIGITAL I/O ORDER

The controller has different sources of I/O which it has to map to IN and OP. This includes I/O from built in I/O, module I/O and CAN I/O. All of these sources are mapped in blocks of 8, some modules have more than 8 I/O so will take up multiple blocks. Any modules using less than 8 will consume a block of 8 and the remainder of the block will be virtual I/O.

By default built in controller I/O is mapped first followed by module I/O then CAN I/O. `MODULE_IO_MODE` is used to configure a different order or to disable the module I/O. When mapping the blocks of separate input and outputs the controller will overlap any inputs and outputs. Please note that bi-directional I/O cannot be split so can cause gaps in the I/O map.

All supported CAN protocols are mapped into the CAN section. For example a system with a MC464, FlexAxis 8, 1 CAN input and 1 CAN output module would be mapped as follows.

I/O source	Inputs	Outputs	I/O
MC464 I/O	0-7		8-15
FlexAxis 8	16-19		20-23
CAN address 0	24-40	24-40	

The FlexAxis is mapped to one block of I/O, as only 4 pins are bi-directional, outputs 16-19 are now virtual.

A different system using a MC464, EtherCAT, 1 CAN input and 1 CAN output module would be mapped as follows.

I/O source	Inputs	Outputs	I/O
MC464 I/O	0-7		8-15
Ethercat	16-23		
CAN address 0	24-40	16-23	

You can see that the EtherCAT inputs and CAN Output module are mapped to the same numbers. It is important to remember that the IN and OP are separate unless they are combined in a bi-directional I/O point.

ANALOGUE I/O ORDER

Up to 32 CAN analogue inputs can be added to the system these are mapped to AIN in order of the module

address. Analogue inputs are mapped as follows:

AIN	Source
0 to 31	CAN analogue inputs
32-33	Built in analogue inputs
33+	Module analogue inputs

Analogue outputs are mapped to AOUT in order of the module address starting at 0.

TrioCANv2 Protocol

GENERAL DESCRIPTION

The MC4xx range controllers by default will use TrioCANv2 protocol, this has various enhancements of previous versions of TrioCAN. The protocol allows for a combination of current and older CAN I/O modules though not all features of TrioCANv2 will be available if a P325, P315 or P316 module is used.

Enhancements to the protocol allow for the following:

- Increase the number of CAN inputs to 256
- Increase the maximum number of CAN outputs to 256
- Increase the total sum of Inputs and Outputs to 512 (bi-directional I/O counts as 1 input and 1 output)
- Allow new analogue output functionality
- Recognise digital input modules
- Recognise digital output modules
- Allow up to 32 digital modules by overlapping input and output addresses.
- Allow expansion module registration inputs and hardware PSWITCH outputs to be used as I/O
- Improved error handling - any error on the network is reported to the controller



If you need to revert to TrioCANv1 protocol you can set `CANIO _ MODE` and `MODULE _ IO _ MODE`. When using `CANIO _ MODE=1` all digital input, output and relay modules are treated as bi-directional I/O modules.

These changes will impact how you address the CAN I/O modules and how the I/O is mapped into the controller.

PROTOCOL SELECTION

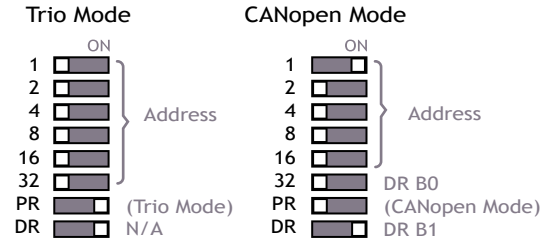

TrioCAN (all versions) can be selected on the CAN I/O modules using the protocol (PR) switch. When the controller initialises the CAN network it will tell the module to either use TrioCANv1 or TrioCANv2. It is recommended to leave the controller using TrioCANv2 however TrioCANv1 can be manually set in the controller using `CANIO _ MODE`.



The data rate is fixed to 500kHz for TrioCANv2 Protocol, the data rate (DR) switch has no function. It is not possible to mix the CAN I/O modules which are running the TrioCANv2 protocol with DeviceNet equipment or CANopen devices on the same network

CONTROLLER SETUP

All *Motion Coordinators* are configured by default to look for a TrioCAN network, MC4xx range controllers will automatically use TrioCANv2 if the modules on the network all support it. To force the controller to always use TrioCANv1 you can set `CANIO _ MODE`.

To automatically search the CAN bus for TrioCAN modules on power up, `CANIO _ ADDRESS` must be set to 32. There is no need to set this as it is the default value.

There are various system parameters available on the controller to check and change the status of the TrioCAN network, these include `CANIO _ STATUS`, `CANIO _ ADDRESS`, `CANIO _ ENABLE` and `CANIO _ MODE`.

When choosing which I/O devices should be connected to which channels the following points need to be considered:

- Inputs 0 - 63 ONLY are available for use with system parameters which specify an input, such as `FWD _ IN`, `REV _ IN`, `DATUM _ IN` etc.
- The built-in I/O channels have the fastest operation <1mS
- CAN input modules with addresses 0-3 have the next fastest operation up to 2mS
- The remaining CAN input modules operate up to 20mS
- Outputs are set on demand.

UPDATE RATES

DIGITAL I/O

The digital I/O are cascaded through the modules, this means that lower address modules have a higher update rate.

Function	Update rate
Inputs address 0-3	2ms, no more than 50ms when state unchanged
Inputs address 4-11	10ms, no more than 50ms when state unchanged
Inputs address 12-15	20ms, no more than 50ms when state unchanged
Output address 0-3	5ms or on change of state
Output address 4-7	6ms
Output address 8-11	6ms (offset by 2ms from outputs address 4-7)
Output address 12-15	6ms (offset by 4ms from outputs address 4-7)

ANALOGUE I/O

Analogue inputs have a standard operation which is enabled by default. Some applications require higher speed updates for example when using the analogue inputs as feedback into a servo loop.

Function	Update rate
Analogue Inputs, standard mode	10ms
Analogue Inputs fast mode	2ms
Analogue outputs	On state change

Standard operation is selected by default by the analogue module on power up. Fast operation has to be selected by executing the following **BASIC** in a configuration or startup program:

```
CAN(-1, 5, 4, $50, 8, 1)
CAN(-1, 7, 4, $04, module_address, $00, $20, $00, $00, $00, $01)
```

DIGITAL CAN I/O ADDRESSING

To enable up to 32 modules on the TrioCANv2 network and up to 512 I/O points Inputs and Outputs are addressed separately. There are 16 addresses (0-15) available for input modules and 16 addresses (0-15) available for outputs. Bi-directional modules take the same address from both the input and output range. There must be no gaps in the input address range, but gaps are allowed in the output address range.



Relay modules are addressed as per digital outputs, they use a block of 16 outputs even though they only have 8.

The total number of digital outputs, digital inputs and total digital I/O are reported by the system parameters NIN, NOP, NIO. The digital configuration is also reported in the startup message.



It is important to remember that **IN** and **OP** are only connected if you are using a bi-directional module. When using Input and Output modules with the same address **IN(x)** and **OP(x)** can be physically different I/O. If you need to read the state of an output you should use **READ _ OP(x)**.

For example a system with 5 CAN 16-Input, 2 16-IO, 7 16-Output and one Relay module could be mapped as per the table below. The CAN I/O start at 16 as the controller has 16 I/O built-in and no module I/O. The start position will move depending on the number of built in I/O and module I/O.

I/O source	Inputs	Outputs	Relay	I/O
Controller I/O	0-7			8-15
CAN address 0				16-31
CAN address 1				32-47
CAN address 2	48-63	48-63		
CAN address 3	64-79	64-79		
CAN address 4	80-95	80-95		
CAN address 5	96-111	96-111		
CAN address 6	112-127	112-127		
CAN address 7			128-135 (136-143 virtual)	
CAN address 8		144-159		
CAN address 9		160-175		

You can see from this chart how the input and output modules are allowed to have overlapping addresses. Bi-directional I/O modules must have a unique address. The relay module only has 8 outputs but uses 1 bank of 16 outputs.

 **TrioCAN (v1) treats all modules as bi-directional I/O and so every module must have a unique address. The total number of I/O points is limited to 256 and the network is limited to 15 modules.**

ANALOGUE I/O ADDRESSING

The address switches on the analogue I/O modules will affect the order in which the I/O is mapped into AIN and AOUT. The first analogue module should be address 16 the second to 17 etc, there should be no gaps in the analogue I/O addressing. The addresses are set as a binary sum so for address 17 both switch 16 and 1 must be ON.

The total number of analogue outputs, analogue inputs and total analogue I/O are reported by the system parameters NAOUT, NAIN, NAIO. The analogue configuration is also reported in the startup message.

The analogue I/O are addressed as per the following table.





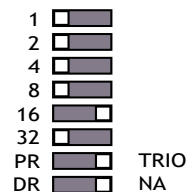

















Address	AIN	AOUT
16	0-7	0-3
17	8-15	4-7
18	16-23	8-11
19	24-31	12-15

Trio Protocol
Address = 16
Analogue Inputs 0..7



ERROR CODES

Once the binary number has been read from the CAN I/O LED's then the error is as per the table below. Please note that only the error LED's are shown.

Code	P317, P318, P319, P327 LEDs	P326 LEDs	Error Description
1			Invalid Protocol
2			Invalid Module Address
3			Invalid Data Rate
4			Uninitialised
5			Duplicate Address
6			Start Pending
7			System Shutdown
8			Unknown Poll
9			Poll Not Implemented
10			CAN Error
11			Receive Data Timeout

TROUBLESHOOTING

If the network configuration is incorrect 2 indications will be seen: The CAN module will indicate an error and the *Motion Coordinator* will report the wrong number of digital or analogue I/O.

If the error is 'uninitialised' then please check:

- Terminating 120 Ohm Network Resistors fitted?
- 24Volt Power to Network?
- Are the addresses correct?

- Have you power cycled the I/O modules after setting the address?
- Cable used is the correct CAN bus specification?
- Is `CANIO _ ADDRESS=32`?

If the network is OK but you are having I/O problems please check:

- 24Volt Power to each I/O bank required?
- You are using the correct I/O in the controller?
- `MODULE _ IO _ MODE` is set as you expect?
- `CANIO _ MODE` is set as you expect?

If the network stops during use please check:

- Terminating 120 Ohm Network Resistors fitted?
- The CAN cable is shielded with the shields correctly connected to earth

Cable used is the correct CAN bus specification?

- Connectors/ wires are not loose

CANopen DS401

GENERAL DESCRIPTION

The CAN modules can support CANopen DS401 so that they can be used with another manufacturers master or with a *Trio Motion Coordinator* and another manufacturer's module on the network.

PROTOCOL SELECTION

CANopen is selected on the CAN I/O modules using the protocol (PR) switch on the module.

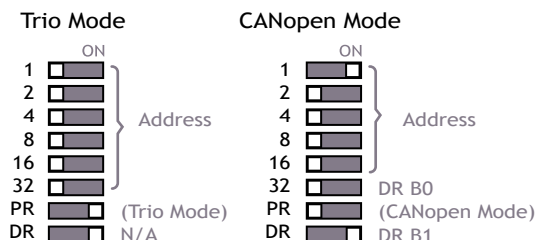

CANopen allows the use of different data rates, this is selected by setting the switches marked 32 and DR. Switch 32 sets bit 0 of the data rate and DR sets bit 1.

(DR B1)	DR (DR B0)	Data Rate
0	0	115K
0	1	250KB

(DR B1)	DR (DR B0)	Data Rate
1	1	500KB
1	1	1Mb

CONTROLLER SETUP

To use CANopen DS402 an initialisation program must be run that configures the network. Examples of this program can be found on the Trio website. Once The CANopen network is configured then you can use the CAN I/O with the standard **IN**, **OP**, **READ _ OP**, **AIN** and **AOUT** *commands as normal.

(*Future software release)

MODULE ADDRESSING

Each CAN I/O module becomes a node on the CANopen network. The address switches are used to assign a unique node number to the module.

ERROR CODES

The power (PWR) and error (ERR) LEDs display the modules current state as per the tables below.

LED STATE DEFINITIONS

LED state	Description
LED on	The LED constantly on.
LED off	The LED constantly off.
LED flickering	The LED flashes on and off with a frequency of approximately 10 Hz.
LED blinking	The LED flashes on and off with a frequency of approximately 2.5Hz: on for approximately 200ms followed by off for approximately 200ms.
LED single flash	The LED indicates one short flash.
LED double flash	The LED indicates a sequence of two short flashes.
LED triple flash	The LED indicate a sequence of three short flashes.
LED quadruple flash	The LED indicates a sequence of four short flashes.

PWR LED ERROR CODE

The PWR LED is used as the 'CANopen run LED' as recommended by CANopen. Its state displays the following:

CAN Run LED	State	Description
Flickering	AutoBitrate/LSS	The auto-bitrate detection is in progress or LSS services are in progress (alternately flickering with error LED)
Blinking	PRE-OPERATIONAL	The device is in state PRE-OPERATIONAL
Single flash	STOPPED	The device is in state STOPPED
Double flash	Reserved for further use	
Triple flash	Program/ Firmware download	A software download is running on the device
On	OPERATIONAL	The device is in state OPERATIONAL

ERR LED ERROR CODE

The ERR LED is used as the ‘CANopen error LED’ as recommended by CANopen. Its state displays the following:

ERR LED	State	Description
Off	No error	The device is in working condition
Flickering	AutoBitrate/LSS	The auto-bitrate detection is in progress or LSS services are in progress (alternately flickering with run LED)
Blinking	Invalid Configuration	General configuration error
Single flash	Warning limit reached	At least one of the error counters of the CAN controller has reached or exceeded the warning level (too many error frames)
Double flash	Error control event	A guard event (NMT-slave or NMTmaster) or a heartbeat event (heartbeat consumer) has occurred
Triple flash	Sync error	The sync message has not been received within the configured communication cycle period time out.
Quadruple flash	Event-timer error	An expected PDO has not been received before the event-timer elapsed
On	Bus off	The CAN controller is bus off

Installing the CAN I/O Modules

PACKAGING

The CAN I/O modules are designed to be mounted on a DIN rail.

The rugged plastic case includes ventilation holes, top and bottom.

The dimensions are shown below.

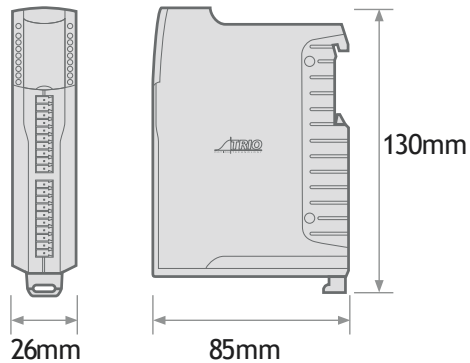

CAN Module Dimensions

ITEMS SUPPLIED WITH CAN I/O MODULES

- 5 way CAN connector
- 2x 10 way I/O connectors
- 2x 120 Ohm terminating resistors
- Quick start guide

MOUNTING CAN I/O MODULES

The CAN I/O modules should be mounted vertically and should not be subjected to mechanical loading. Care must be taken to ensure that there is a free flow of air vertically around the CAN I/O module.

To mount pull down the sprung loaded clip, slot over the DIN rail and release the clip to lock the module to the rail.

